

Quantitative Methods

Simpson's Rule Volume

Module No. Cons 1012

Lecturer Jennifer Byrne

Simpson's Rule Volume

- Simpson's Rule is used to calculate the area of an irregular surface.
- The surface is measured using Ordinates (or Lengths).
- For Simpson's Rule for Volume first you need to calculate the cross sectional areas at the ordinates at regular intervals .
- Once you have calculated these you can then insert into the formula.
- $\text{Area} = W/3 \{ (\text{first} + \text{last}) + 4 (\text{evens}) + 2 (\text{odds}) \}$

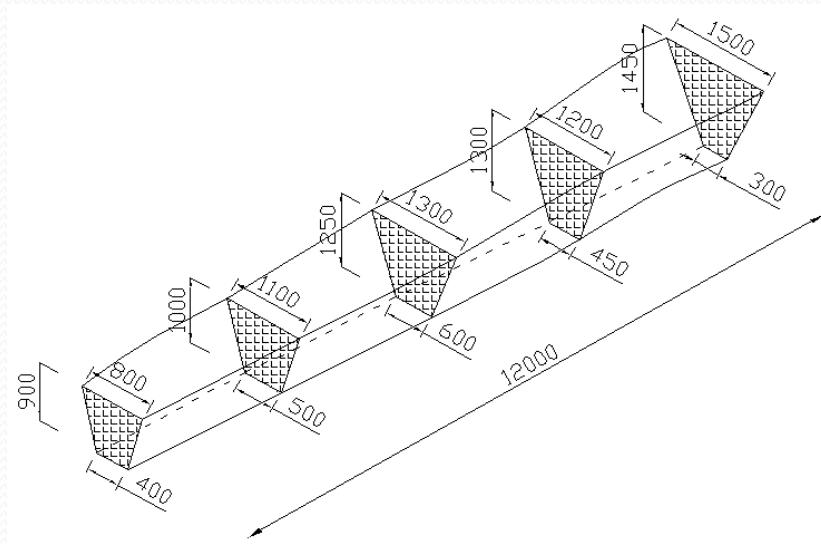

All measurements are in mm

Simpson's Rule Volume

- Calculate the volume of soil required to backfill the excavated trench shown using Simpson's rule for volume.
- Before being compacted into the trench, the loose soil is bulked by 35%, so what is the actual bulked volume of soil required?
- $\text{Area} = W/3 \{ (\text{first} + \text{last}) + 4 (\text{evens}) + 2 (\text{odds}) \}$

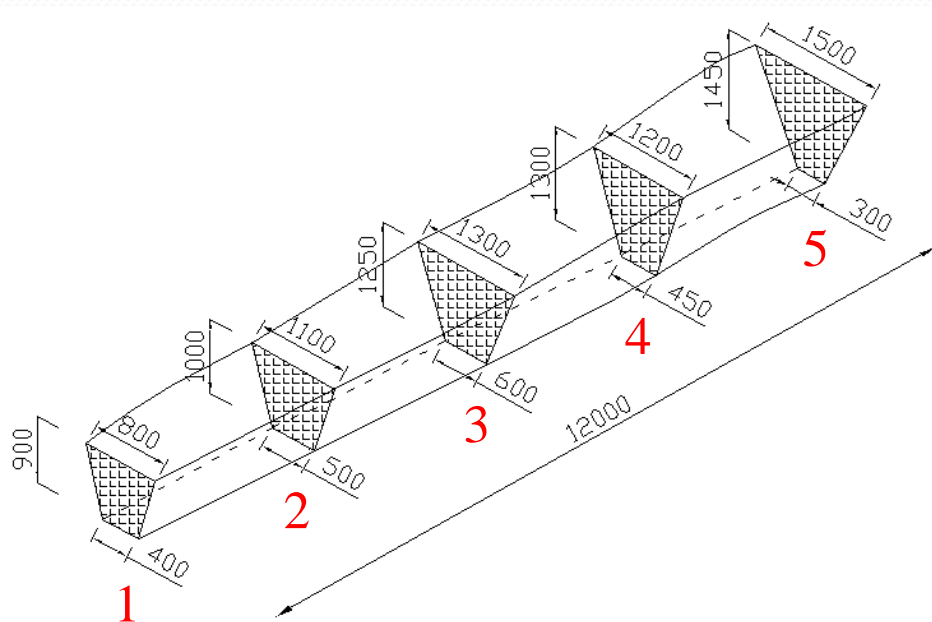

All measurements are in mm

Simpson's Rule Volume

- First calculate cross sectional areas using the trapezoid formula: $\frac{a + b}{2} \times \text{height}$
- Cross sectional area (1) $\left\{ \frac{0.8 + 0.4}{2} \right\} \times 0.9 = 0.54 \text{ m}^2$
- Cross sectional area (2) $\left\{ \frac{1.1 + 0.5}{2} \right\} \times 1.0 = 0.80 \text{ m}^2$
- Cross sectional area (3) $\left\{ \frac{1.3 + 0.6}{2} \right\} \times 1.25 = 1.1875 \text{ m}^2$
- Cross sectional area (4) $\left\{ \frac{1.2 + 0.45}{2} \right\} \times 1.3 = 1.0725 \text{ m}^2$
- Cross sectional area (5) $\left\{ \frac{1.5 + 0.3}{2} \right\} \times 1.45 = 1.305 \text{ m}^2$

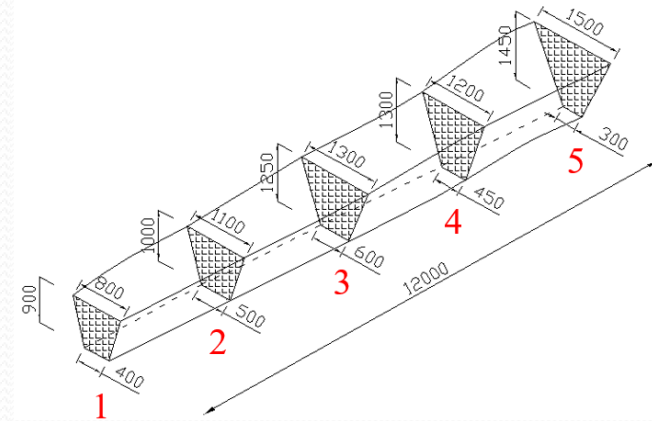

All measurements are in mm

Simpson's Rule Volume

First calculate cross sectional areas
using the trapezoid formula: $\frac{\{a + b\}}{2} \times \text{height}$

$$\text{Cross sectional area (1)} \quad \left\{ \frac{0.8 + 0.4}{2} \right\} * 0.9 = 0.54 \text{ m}^2$$

$$\text{Cross sectional area (2)} \quad \left\{ \frac{1.1 + 0.5}{2} \right\} * 1.0 = 0.80 \text{ m}^2$$

$$\text{Cross sectional area (3)} \quad \left\{ \frac{1.3 + 0.6}{2} \right\} * 1.25 = 1.1875 \text{ m}^2$$

$$\text{Cross sectional area (4)} \quad \left\{ \frac{1.2 + 0.45}{2} \right\} * 1.3 = 1.0725 \text{ m}^2$$

$$\text{Cross sectional area (5)} \quad \left\{ \frac{1.5 + 0.3}{2} \right\} * 1.45 = 1.305 \text{ m}^2$$

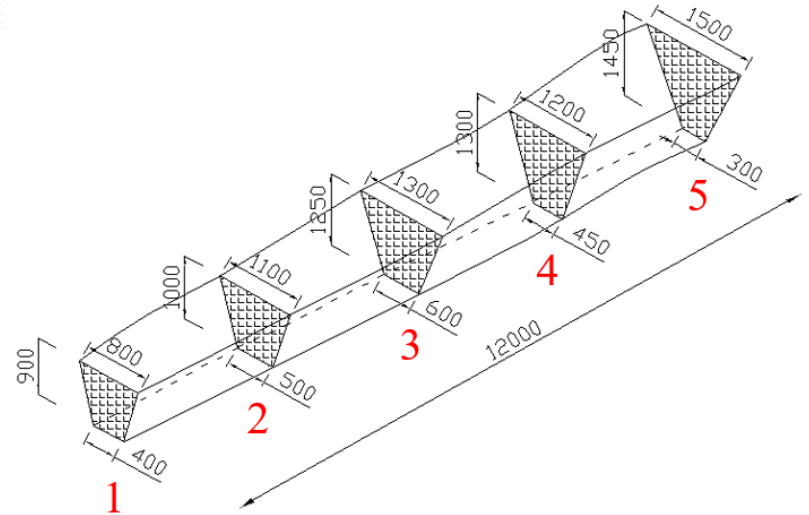

All measurements are in mm

Simpson's Rule Volume

- Simpsons Rule = $\frac{W}{3} \{ (\text{first} + \text{last}) + 4 (\text{evens}) + 2 (\text{odds}) \}$
 - = $\frac{3}{3} \{ (0.54 + 1.305) + 4(0.8+1.0725) + 2(1.1875) \}$
 - = $1 \{ (1.845) + 4(1.8725) + 2(1.1875) \}$
 - = $1 \{ 1.845 + 7.49 + 2.375 \}$
 - = 1×11.71
 - = 11.71 m^3

- Bulking: $11.71 \times 1.35 = \mathbf{15.8085 \text{ m}^3}$

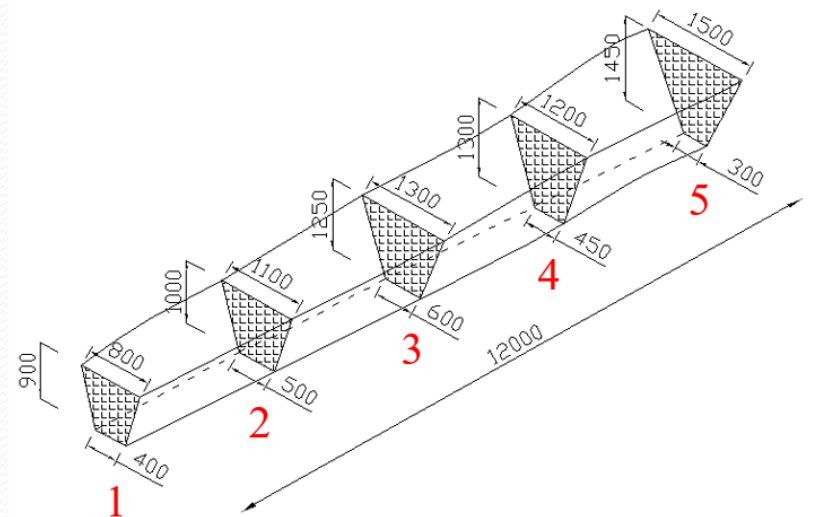

All measurements are in mm